



MAYTAG® COMMERCIAL DEPENDABLE CARE® MULTI-LOAD STACK DRYER

LAUNDRY SOLUTIONS
YOU CAN **DEPEND** ON.

BUILT LIKE A TANK

The MLG45PDB is one of the heaviest 45-pound stack dryers on the market, offering years of dependable Maytag performance.

MICROPROCESSOR CONTROLS

Maytag® Computer Trac® controls let you adjust prices by cycle, day and time — and they provide simple one-touch cycle selection.



FOR YOUR CUSTOMERS:

- Fast-Drying Axial Airflow System
- ThermoGuard™ System Helps Prevent Laundry Overheating
- Extra-Large Door Openings
- Digital Display Shows Time Remaining In Cycle

FOR YOUR OPERATION:

- Single Coin Box For Both Dryers
- Front Access For Easy Service
- Two 8" Vents Or One Optional 10" Vent
- 2 Large-Capacity Lint Drawers

BUILT-TO-LAST™ FEATURES:

- Heavy-Duty Enclosed Motors
- Permanently Lubricated Bearings
- Rear Belt Drive System
- The Best Warranty In The Business

MLG45PDB



HERMOGUARD™ SYSTEM
**PROTECTS
LAUNDRY**
AGAINST OVERHEATING.

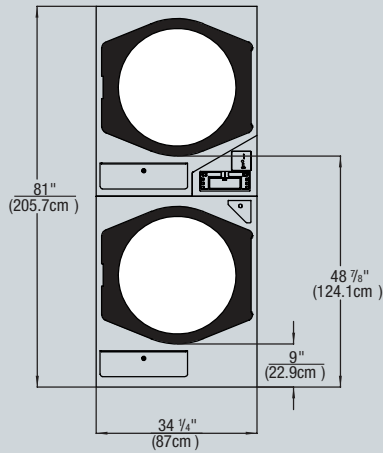

FRONT VIEW

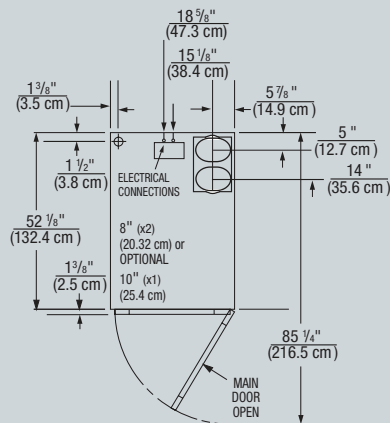

TOP VIEW

*Dimensions will vary according to adjustment of leveling legs; add 1/2" (1.3 cm) minimum.

Maytag® Dependable Care® Multi-Load Stack Dryer

MICROPROCESSOR COIN-DROP

		Dependable Care® Multi-Load Stack Dryer
DRYER SPECIFICATIONS		
MODEL		MLG45PDB
MOTOR		
Single-phase, thermoprotected against overload, auto-reset		•
HP (kw)		.75 (.56)
CAPACITY		
Lbs. (kg) per drying chamber		45 (20.41)
Cu. ft. (L) per drying chamber		14.6 (413.43)
AIRFLOW		
Cfm (cmm) per drying chamber		600 (16.99)
TUMBLERS		
Diameter — in. (cm)		32.75 (83.19)
Depth — in. (cm)		30 (76.2)
DOOR OPENING DIAMETER		
In. (cm)		27 (68.6)
ELECTRICAL REQUIREMENTS		
BREAKER/FUSE REQUIREMENTS		
Amps per drying chamber		20
EXHAUST DUCT DIAMETER		
In. (cm)		8 (20.3)
GAS RATING		
BTU/hr. (kcal/hr.) per drying chamber		112,000 (28,230)
GAS INLET PER POCKET		
In. (cm)		3/4 (1.9)
ADJUSTABLE LEVELING LEGS		
		•
COLORS		
White		•
Stainless Steel		•
APPROXIMATE WEIGHT		
Crated — lbs. (kg)		1050 (476)
Uncrated — lbs. (kg)		1015 (460)
See specific instructions for proper installation. Because of continuous product improvement, Maytag reserves the right to change specifications without notice.		



NEW YORK CITY
M.E.A.



5 YEARS — ALL PARTS

For a period from the date of original purchase through the time listed above, the designated parts that fail in normal commercial use will be repaired or replaced free of charge for the part itself, with the owner paying all other costs, including labor, transportation and customs duty. Chemical damage is excluded from all warranty coverage. See complete warranty for details.

