



SPEED QUEEN® MULTI-HOUSING LAUNDRY SOLUTIONS

Hardmount Washer-Extractor

SCT030

30 lb (13.6 kg)

Built for Reliable Performance

Speed Queen® machines are built specifically for the commercial environment. We use steel where others use plastic. Our world-class test lab rigorously pushes our products far beyond the conditions they'll face in the field. We believe in being there when our customers need us most. And we go the extra mile at every point of the manufacturing process to ensure that our machines reflect that belief. With Quantum® controls, it's easy to customize your laundry operation to meet your needs. This revolutionary technology unites equipment controls, programming and revenue management into one versatile system.

- Advanced inverter drive provides smooth, reliable power – saving you 33% on electricity versus previous models

- Faster extraction speed on Quantum® Gold machines have up to 200 G-Force extraction to remove more water, leading to shorter dry times.
- Leak detection saves water by detecting slow or leaking fill-valves and drains
- Stronger frame design lasts longer, balances loads more efficiently and is pallet jackable, making it easier to install
- Quiet performance reducing sound and vibration levels
- Four compartment dispenser
- Automatic door lock
- Secure high-capacity coin vault
- Commercial grade bearings, shaft and seal
- Ergonomic door handle
- Front service access
- Available with pump drain option



Quantum® Gold

Cutting edge Quantum® control system from Speed Queen® gives you the freedom to manage laundry your way and the power to achieve unmatched levels of revenue. This revolutionary technology provides users with more cycle choices than ever, offers unprecedented options to help lower operating costs and incorporates tools and options to increase revenue.

Hardmount Washer-Extractor

Specifications

		SCT030	
Control Option		Quantum Gold	
Color		Stainless Steel	
Capacity - lb (kg)		30 (13.6)	
Overall Width - in (mm)		29 (737)	
Overall Depth - in (mm)		35.3 (897)	
Overall Height - in (mm)		45 (1143)	
Cylinder Diameter - in (mm)		24 (610)	
Cylinder Depth - in (mm)		16 (406)	
Cylinder Volume - cu. ft (liters)		4.2 (119)	
Door Opening Size - in (mm)		14.3 (363)	
Water Inlet Connection - in (mm)		2 x 0.75 (19)	
Drain Diameter - in (mm)		1 x 3 (76)	
Drain Height to Floor - in (mm)		4.3 (109)	
Motor Power Consumption - HP (kW)		1 (0.75)	
Total Number of Speeds		6,9	
Cylinder Speeds - RPM (G-Force)	Gentle	34 (0.4)	
	Wash	48 (0.8)	
	Distribution	86 (2.5)	
	Very Low	282 (27)	
	Low	485 (80)	
	Medium	542 (100)	
	High	606 (125)	
	Very High	664 (150)	
	Ultra High	766 (200)	
** Voltage Wires/ Circuit Breaker - FLA	B	120/60/1	15-12
	X	200-240/50-60/1/3	15-7 (1 Ph) 15-4 (3 Ph)
	Y	220-240/60/1/3 (Pump Drain Only)	15-7 (1 Ph) 15-4 (3 Ph)
Shipping Dimensions Approx.- in (mm)	Width	31.5 (800)	
	Depth	38.3 (973)	
	Height	51.3 (1303)	
Net Weight - lb (kg)		440 (200)	
Shipping Weight - lb (kg)		480 (218)	
***Agency Approvals		cULus	

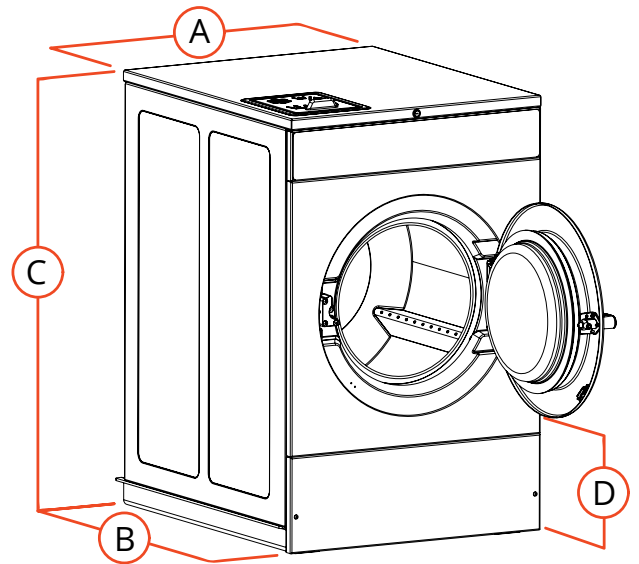

A.	Overall Width - in (mm)	29 (737)
B.	Overall Depth - in (mm)	35.3 (897)
C.	Overall Height - in (mm)	45 (1143)
D.	Floor to Door Opening - in (mm)	14 (356)

* Overall depth includes vacuum breaker to door handle.

** Circuit breaker and amp draw data shown are for models without electric heat. Consult factory for other configurations. Manufacturer strongly recommends using a circuit breaker instead of fuses. Use 3-pole circuit breaker for 3-phase machines.

*** Agency approvals may vary depending on configuration. Consult factory for details.

For the most accurate information, the installation guide should be used for all design and construction purposes. Due to continuous product improvements, design and specifications subject to change without notice. The quality management systems at Alliance Laundry Systems are registered to ISO 9001.