



SPEED QUEEN® MULTI-HOUSING LAUNDRY SOLUTIONS

Stack Dryer – Short – Solid Door

Quantum® Gold Pro

Prep for Card | Coin Drop Installed

Built for Reliable Performance

Speed Queen's stack dryer offers the same great features as the single load dryer. Two commercial dryers in the space of one, both operating independently, including independent controls for optimum usage. Defined by its simplicity and its performance, Speed Queen provides everything you need to get the job done - and nothing you don't. Speed Queen's stack dryer combines heavy-duty construction with reliable operation proven to stand the test of time. They're designed with less moving parts for one reason: so you'll face fewer maintenance problems and less wear and tear down the road. Speed Queen's dryers provide the perfect balance of heat, airflow and tumble action for optimal performance and efficiency. Bottom dryer is ADA compliant.

- Integrated meter case
- Industry's largest door opening 2.06 sq. ft. (1914 cm²)
- Quiet, efficient blower system
- High efficiency exhaust blower with superior airflow 220 cfm (105 liters/sec)
- 100% serviceable from the front
- Space-saving narrow cabinet 26.875" (683 mm) Height 76.5" (1943 mm)
- Upfront lint filter easy to clean and secured
- Durable galvanized steel cylinder
- Large capacity meter case standard

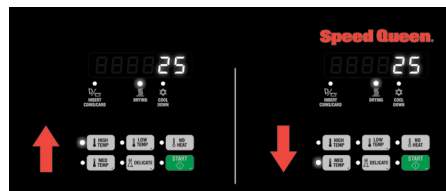



Quantum® Gold Pro Control

The Quantum® Gold Pro control delivers a truly premium experience to residents. From intuitive soft touch buttons that walk them through cycle options to multiple actuations (coin, card, mobile) for payment flexibility, this control gives residents the wash and dry options they want, and the revenue potential managers desire.

Stack Dryer – Short – Solid Door

Quantum® Gold Pro

| Specifications | | |
|--|----------|---------------------------------------|
| Control Option | | Quantum Gold Pro |
| Color | | White |
| Capacity - lb (kg) | | 18 (8.2) ea |
| Overall Width - in (mm) | | 26.875 (683) |
| Overall Depth - in (mm) | | 28 (711) |
| Overall Height - in (mm) | | 76.5 (1943) |
| Cylinder Volume - cu. ft. (liters) | | 7.0 (198) ea |
| Motor (Thermal Protected) | | 0.33 HP |
| Type Of Gas (Gas Models Only) | | Factory equipped natural |
| Air Outlet Diameter - in (mm) | | 4 (102) |
| Exhaust Airflow - cfm (liters/sec) | | 220 (105) |
| Available Cycles | | High, Medium, Low, Delicates, No Heat |
| Electrical Requirements | Electric | 120/208-240/60/1-30 amp |
| | Gas | 120/60/1-15 amp |
| Heating Element | Electric | 5350W, 240V 4750W, 208V |
| | Gas | 25,000 Btu |
| Shipping Dimensions Approx. - in (mm) | Width | 33 (838) |
| | Depth | 30 (762) |
| | Height | 80 (2032) |
| Net Weight - lb (kg) | Electric | 270 (122.5) |
| | Gas | 270 (122.5) |
| Shipping Weight - lb (kg) | Electric | 280 (127) |
| | Gas | 280 (127) |
| Agency Approvals | Electric | cULus |
| | Gas | cCSAus |

| Models | Voltage/Freq/PH | Actuation | |
|-----------------|-----------------|-----------|---|
| SSENCFGS176TW01 | 208-240/60/1 | Electric | Coin Drop Installed  |
| SSGNCFGS116TW01 | 120/60/1 | Gas | |
| SSENYFGS176TW01 | 208-240/60/1 | Electric | Prep for Card  |
| SSGNYFGS116TW01 | 120/60/1 | Gas | |

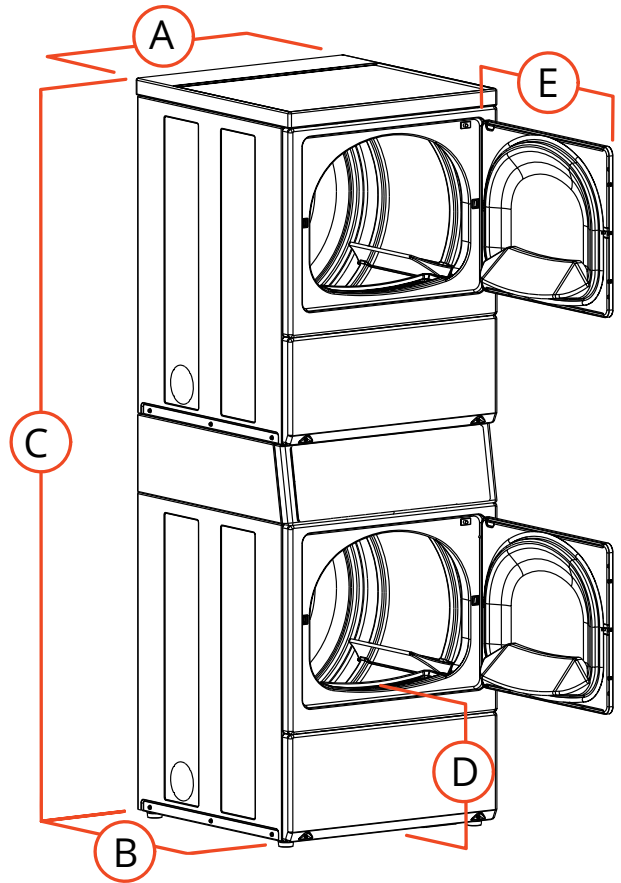

| | |
|-----------------------------------|--------------|
| A. Overall Width - in (mm) | 26.875 (683) |
| B. Overall Depth - in (mm) | 28 (711) |
| C. Overall Height - in (mm) | 76.5 (1943) |
| D. Floor To Door Opening -in (mm) | 15.44 (392) |
| E. Door Swing - in (mm) | 23.5 (597) |

NOTE: Each stack dryer pocket requires its own separate power cord (not supplied).

Electric dryers come equipped for 208-240/60/1 operation. They can be field converted to operate on 208/60/1 with optional 61928 conversion kit.

Gas dryers can be field converted for operation on LP gas with optional 458P3 conversion kit.

For the most accurate information, the installation guide should be used for all design and construction purposes. Due to continuous product improvements, design and specifications subject to change without notice. The quality management systems at Alliance Laundry Systems are registered to ISO 9001.

Commercial product is not authorized for sale to Residential end consumers.