



SPEED QUEEN® MULTI-HOUSING LAUNDRY SOLUTIONS

Rear Control Single Dryer

Electronic Homestyle

Built for Reliable Performance

Speed Queen® single load dryers are durably constructed using premium materials for long-lasting, reliable performance and superior wash results. If you want your laundry done right, you want a Speed Queen. Our machines are manufactured using metal instead of plastic. They're built with rugged, commercial-grade construction and pushed beyond their limit in our state-of-the-art test lab, ensuring unmatched durability. Our world-class test lab rigorously pushes our products far beyond the conditions they're likely to ever face. We work hard at every point of our manufacturing process to ensure that our machines reflect that belief.

- Industry's largest door opening 2.06 sq. ft. (1914 cm²)
- Door is reversible for installation flexibility
- High efficiency exhaust blower with superior airflow 220 cfm (105 liters/sec)
- 100% serviceable from the front
- Space-saving narrow cabinet 26.875" (683 mm)
- Moisture sensing technology
- Upfront lint filter easy to clean and secured
- Durable galvanized steel cylinder
- Efficient and fast dry cycle
- Extra-large capacity

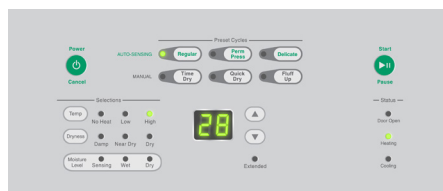

Electronic Homestyle Control

Electronic Homestyle control is designed for durability and easy operation with attractive selection buttons and cycle status indicator lights.

Rear Control Single Dryer

Electronic Homestyle

Specifications		
Control Option		Electronic Homestyle
Color		White
Capacity - lb (kg)		18 (8.2)
Cylinder Volume - cu. ft. (liters)		7.0 (198)
Motor (Thermal Protected)		0.33 HP
Type Of Gas (Gas Models Only)		Factory equipped natural/mixed gas
Air Outlet Diameter - in (mm)		4 (102)
Exhaust Airflow - cfm (liters/sec)		220 (105)
Available Cycles		Regular, Permanent Press, Delicate, Time Dry, Quick Dry, Fluff Up
Electrical Requirements	*Electric	120/240/60/1-30 amp
	Gas	120/60/1-15 amp
Heating Element	Electric	5350W, 240V
	Gas	25,000 Btu
Net Weight - lb (kg)	Electric	126 (57.2)
	Gas	126 (57.2)
Shipping Weight - lb (kg)	Electric	136 (61.7)
	Gas	136 (61.7)
Shipping Dimensions Approx. - in (mm)	Width	30.5 (775)
	Depth	29.5 (762)
	Height	45 (1143)
Agency Approvals	Electric	cULus
	Gas	cCSAus

Models	Voltage/Freq/PH	
LDDE7RGS173TW01	208-240/60/1	Electric
LDGE7RGS113TW01	120/60/1	Gas

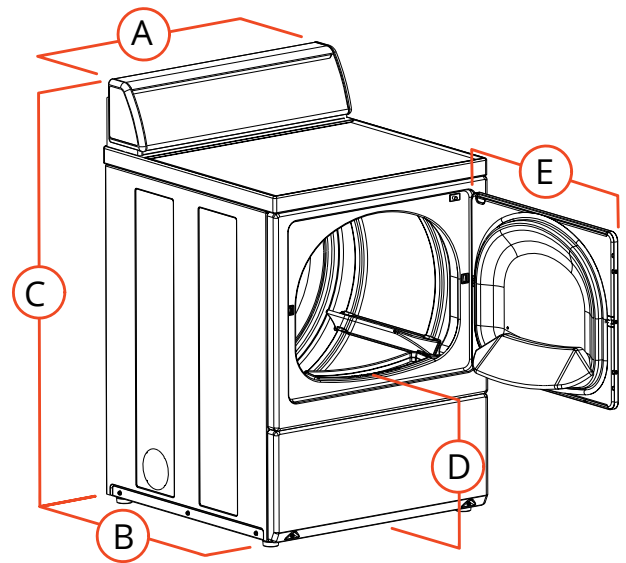

A. Overall Width - in (mm)	26.875 (683)
B. Overall Depth - in (mm)	28 (711)
C. Overall Height - in (mm)	43 (1092)
D. Floor To Door Opening -in (mm)	15.44 (392)
E. Door Swing - in (mm)	23.5 (597)

*Electric dryers come equipped for 240/60/1 operation. They can be field converted to operate on 208/60/1 with optional 61928 conversion kit. Gas dryers can be field converted for operation on LP gas with optional 458P3 conversion kit.

For the most accurate information, the installation guide should be used for all design and construction purposes. Due to continuous product improvements, design and specifications subject to change without notice. The quality management systems at Alliance Laundry Systems are registered to ISO 9001.